

# THE CLEVELAND VIBRATOR CO.

Since 1923, manufacturing quality industrial vibrators and vibratory equipment

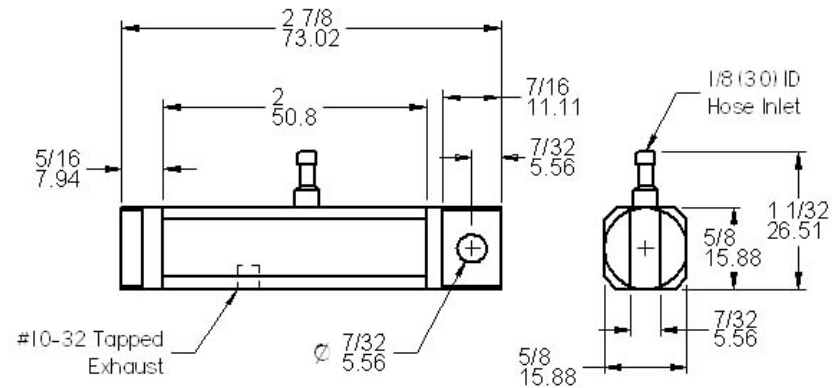

When a little more force than our VM 25 is needed but a miniature is still required, our new VM 38 is just the ticket.

Smaller than our 1/2 SA-EP, the VM 38 is excellent for promoting the flow of materials in bins and hoppers.

It can be supplied with a muffler to prevent contamination and reduce noise levels

At 80 psi, it uses 2.1CFM, vibrates at 11,400 vibrations per minute and produces 21 pounds of force.