

# CLEVELAND VIBRATOR GRAVITY FLOW SCREENERS SINGLE DECK AND DOUBLE DECK

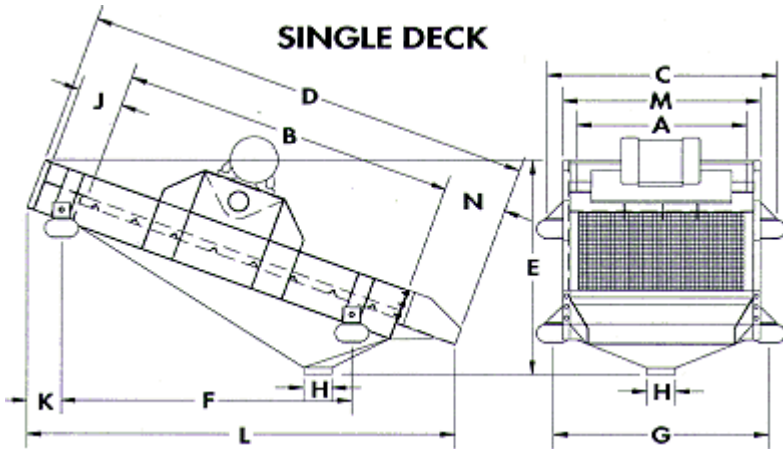

All dimensions are in inches. Dimensions are based on an installation angle. Normal installation angle is 20°.

The gravity flow design is down sloped twenty degrees for gravity-assisted product conveyance, utilizing a single rotary electric vibrator drive.

Model Nomenclature	SC-E	12	36	RE 3-4
	Model Group	Effective Width	Effective Length	Drive Model

MODEL NO.	effective screen area sq ft	A	B	C	D	E	F	G	H	J	K	L	M	N	SHIP WT
SC-E - 1236	3	12	36	31-1/4	51-1/2	23-1/4	22-1/2	27-1/4	6	8	10	46-3/4	19-1/4	6	235 lbs.
SC-E - 1848	4 1/2	18	48	37-1/4	63-1/2	29	30	33-1/4	6	8	10	57-7/8	25-1/4	6	300 lbs.
SC-E - 2448	8	24	48	43-1/4	63-1/2	29	30	39-1/4	6	8	10	57-7/8	31-1/4	6	350 lbs.
SC-E - 3660	15	36	60	59-1/4	77-1/2	37-1/4	37-1/2	53-1/4	8	10	12 1/2	70-1/2	43-1/2	6	650 lbs.
SC-E - 4872	24	48	72	71-1/4	93-1/2	51	45	65-1/4	12	12	15	85	55-1/4	8	785 lbs.
SC-E - 4896	32	48	96	71-1/4	117-1/2	62	52-1/2	65-1/4	12	12	15	107-1/2	55-1/4	8	950 lbs.

**THE CLEVELAND VIBRATOR COMPANY**  
**2828 CLINTON AVE. CLEVELAND, OH 44113**  
**800-221-3298**

# CLEVELAND VIBRATOR GRAVITY FLOW SCREENERS SINGLE DECK AND DOUBLE DECK

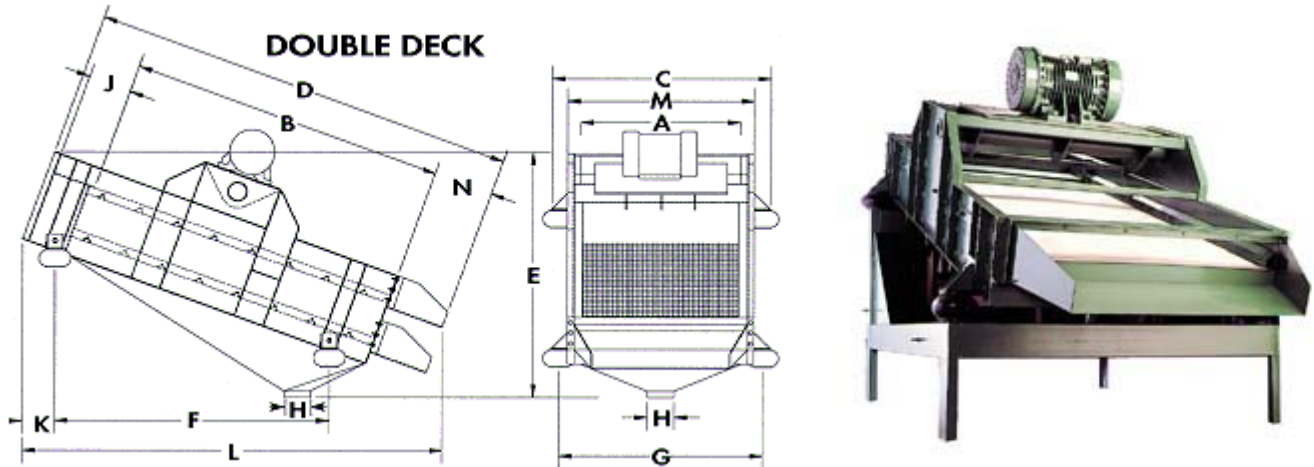

Model Nomenclature	SC-E	12	36	RE 3-4
	Model Group	Effective Width	Effective Length	Drive Model

MODEL NO.	EFFECTIVE SCREEN AREA SQ. FT.	A	B	C	D	E	F	G	H	J	K	L	M	N	SHIP WT.
SC-E - 1236	3	12	36	31-1/4	51-1/2	23-1/4	22-1/2	27-1/4	6	8	10	46-3/4	19-1/4	6	235 lbs.
SC-E - 1848	4-1/2	18	48	37-1/4	63-1/2	29	30	33-1/4	6	8	10	57-7/8	25-1/4	6	300 lbs.
SC-E - 2448	8	24	48	43-1/4	63-1/2	29	30	39-1/4	6	8	10	57-7/8	31-1/4	6	350 lbs.
SC-E - 3660	15	36	60	59-1/4	77-1/2	37-1/4	37-1/2	53-1/4	8	10	12-1/2	70-1/2	43-1/2	6	650 lbs.
SC-E - 4872	24	48	72	71-1/4	93-1/2	51	45	65-1/4	12	12	15	85	55-1/4	8	785 lbs.
SC-E - 4896	32	48	96	71-1/4	117-1/2	62	52-1/2	65-1/4	12	12	15	107-1/2	55-1/4	8	950 lbs.

**THE CLEVELAND VIBRATOR COMPANY**  
 2828 CLINTON AVE. CLEVELAND, OH 44113  
 800-221-3298