

THE CLEVELAND VIBRATOR CO.

Since 1923, manufacturing quality industrial vibrators and vibratory equipment

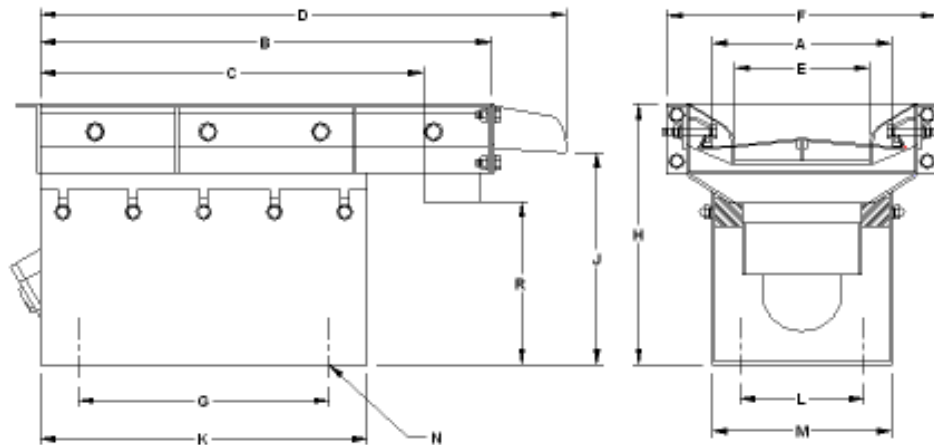

AIR-POWERED SCREENERS



All dimensions are in inches. Have dimensions certified for installation purposes.

SF-A SERIES		LIGHT DUTY AIR-POWERED SCREENERS												
MODEL	A TROUGH WIDTH	B TROUGH LENGTH	C	D	E	F	G	H	J	K	L	M	N	R
SF-A-316-100	3	16	14	18	2	6-1/2	8	9-1/2	7	10	4	6-1/4	5-16	6-1/2
SF-A-420-125	4	20	17	23	3	7-1/2	10	11-1/2	8	12	4-1/2	6-3/4	7/16	6-3/4
SF-A-624-200	6	24	21	27	4	9-1/2	14	12-1/2	9	16	5-1/2	7-3/4	7/16	7-3/4
SF-A-830-300	8	30	26	34	5	13	16	17	13	20	11-3/4	11-3/4	7/16	11

CLEVELAND VIBRATOR COMPANY
2828 Clinton Avenue
Cleveland, Ohio 44113



Phone: 216-241-7157
phone: 1-(800) 221-3298
Fax: 216-241-3480
Email: sales@clevelandvibrator.com

THE CLEVELAND VIBRATOR CO.

Since 1923, manufacturing quality industrial vibrators and vibratory equipment

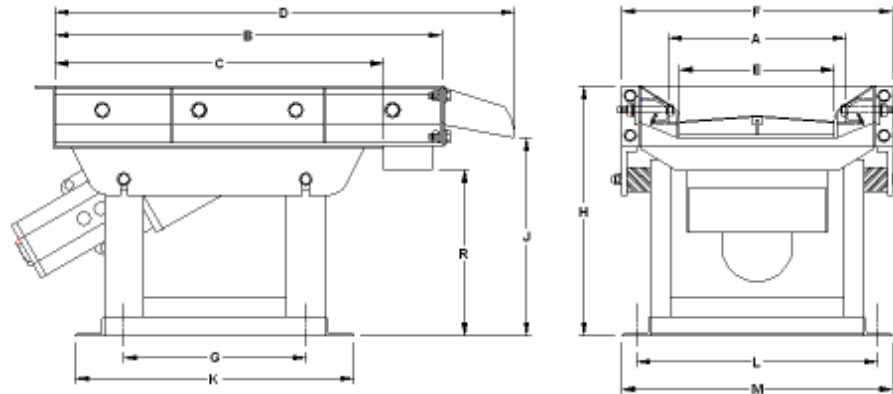

All dimensions are in inches. Have dimensions certified for installation purposes.

SF-A SERIES		MEDIUM & HEAVY DUTY AIR-POWERED SCREENERS												
MODEL	A TROUGH WIDTH	B TROUGH LENGTH	C	D	E	F	G	H	J	K	L	M	N	R
SF-A-1236-350	12	36	32	40	8	18-1/4	24	17	13	26	18-1/4	20-3/4	9/16	11
SF-A-1842-400	18	42	36	48	12	25-1/4	27	24	19	32	19-1/2	21-1/2	9/16	15
SF-A-2448-500	24	48	42	54	16	31-1/4	33	30	25	38	25-1/2	27-1/2	9/16	21

CLEVELAND VIBRATOR COMPANY
2828 Clinton Avenue
Cleveland, Ohio 44113



Phone: 216-241-7157
phone: 1-(800) 221-3298
Fax: 216-241-3480
Email: sales@clevelandvibrator.com